



Available finish:- Black

Read these instructions before commencing installation. Please give these instructions to the owner/occupier after installation to retain for future reference/maintenance.

IP65 IK10 240V~50Hz 20W

These fittings are Class I and must be Earthed

**Important Information**

It is recommended that these luminaires are installed and fitted by a qualified electrician ensuring the installation complies with current IEE wiring regulations & local building control. These products are designed for connection to a 240V~50Hz supply.

Any faulty, broken or damaged luminaires should be replaced immediately.

KSR will not accept responsibility for any claims arising from a poor installation.

Please Note: The limited warranty shall be deemed null and void in the following circumstances: Failure by the installer, end user or any third party to exercise caution to protect any covered product or part from outside damage, adverse temperature (normal operating ambient temperature -15 ~ +40°C), humidity conditions, fluctuations in the electrical system or physical abuse as well as failure related to workmanship in the installation of the products or parts.

**Important User Advice**

Always switch off mains supply before servicing and maintenance.

Please ensure that a suitable maintenance schedule is performed including greasing all moving parts and protection from exposure to natural elements in the form of a non-abrasive cleaner/water repellent protection to ensure the product gives you a long lasting trouble free life.

**Installation Procedure**

Safely isolate the mains supply before installation.

Make up fixing kit as per Figure 1 dig a hole at least 260mm x 260mm square by 200mm deep.

Direct suitable cable from the source to the centre of the hole making sure there is enough cable to reach the terminal block for the bollard you have purchased.

Pour concrete into the hole and while still wet insert the fixing kit ensuring that the threaded bar protrudes the correct length to fit the bollard base.

Once the concrete has set, fix the bollard base to the fixing kit using the spring washers and nuts provided as per Figure 2.

Remove the head by loosening the 3 grub screws.

Remove the driver tray by turning anticlockwise route the cable through the cable gland (8mm-12mm) and terminate wiring as per Figure 3. Tighten the cable gland ensuring a water tight connection.

Select the LED colour you require using the switch on the driver casing.

Refit the driver tray in reverse of removal ensuring the seal is in place (Insert the seal into the head not around the tray).

Refit the bollard head ensuring the head locates onto the 3 lugs in the body, grease the 3 grub screws and tighten.

Turn mains supply on and test luminaire.

**Do Not** expose luminaire to areas where high pollution and saline maybe present.

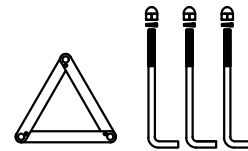

**Supplied Concrete Mount Fixing Kit**

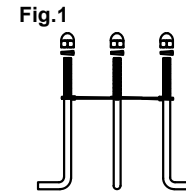
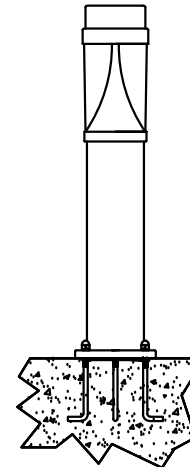

Fig.2



**Important Notes**

- Do not cover or bury the base.
- Ensure product is fitted to an even and stable surface.
- Do not force or overtighten the anchor bolts this can put a strain on the other fixings.

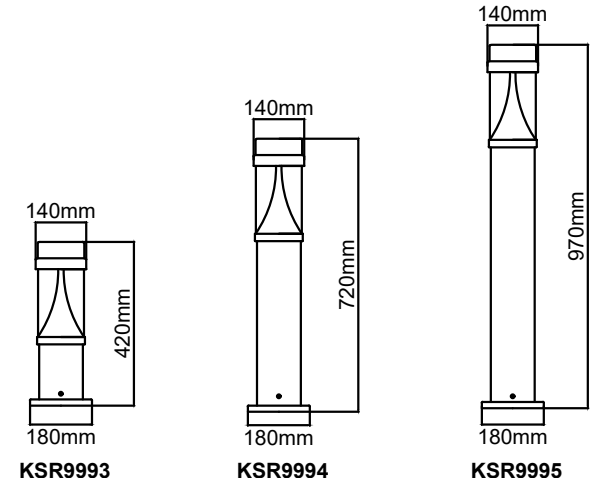
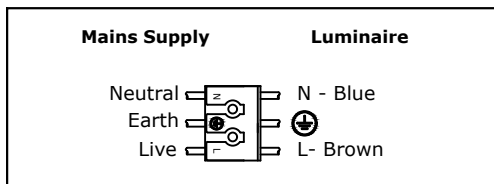

Fig.3



**Lamp Details**

Lamp: Dedicated LED  
 Wattage: 20W  
 Colour: Switchable 3000K - 4000K - 6000K  
 3000K Lumen Output: 1528 lumens  
 4000K Lumen Output: 1724 lumens  
 6000K Lumen Output: 1535 lumens  
 CRI: Ra>82

**The light source of this luminaire is not replaceable; when the light source reaches its end of life the whole luminaire shall be replaced**



*This product contains a light source of energy efficiency class F*

KSR Lighting Aftersales: 023 92 674343  
 E-mail: aftersales@ksrlighting.com



Read these instructions before commencing installation. Please give these instructions to the owner/occupier after installation to retain for future reference/maintenance.

## Concrete Mount Kit Guidance

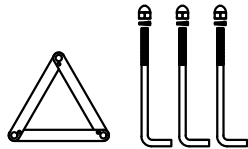

**Important Notes**

- Do not cover or bury the base.
- Ensure product is fitted to an even and stable surface.
- Do not force or overtighten the anchor bolts this can put a strain on the other fixings.

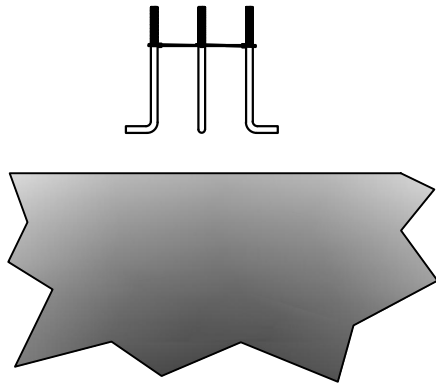

Choose a suitable Location to mount Bollard and assemble concrete mounting Kit.

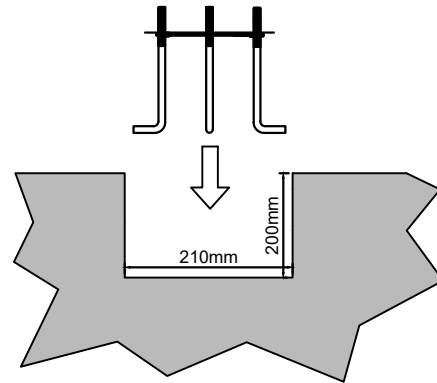

Prepare a hole 260mm (L) x 260mm (W) x 200mm deep (D), proceed to fill hole with wet concrete mix and ensure hole is smooth and leveled off, the fixing kit should be square to the hole prepared with fixing threads exposed. Make provision for supply cable ensuring any in ground/in line connector is suitably rated and watertight.

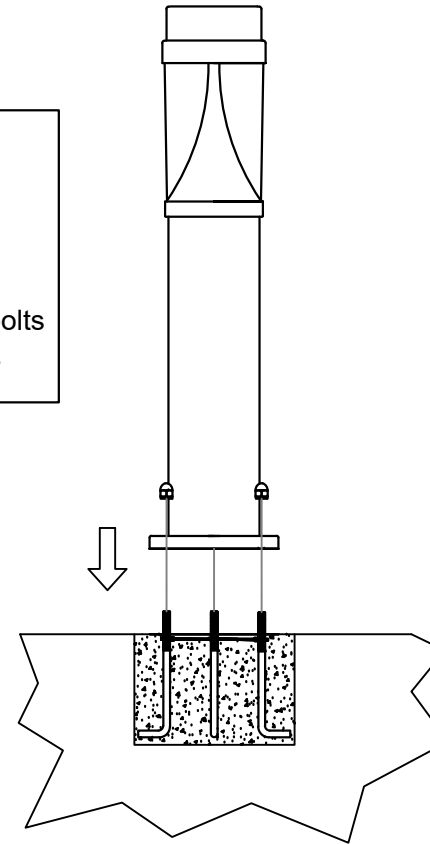

With the Concrete mount kit set proceed to attach bollard base to root mount kit threaded rods ensuring that when the base is tightened down that the locking nuts are evenly tightened.

**Please Note : To Avoid damage to the base of the bollard do not overtighten**

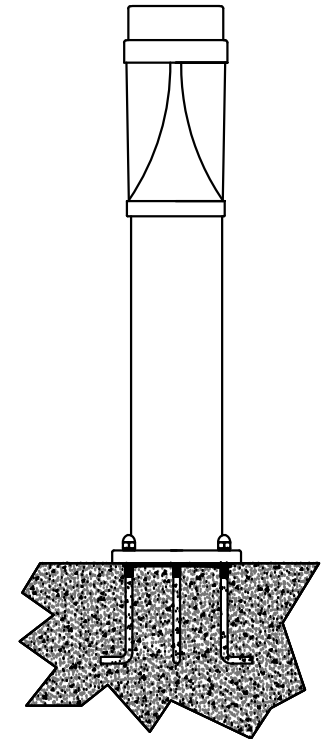

With Bollard now securely mounted to concrete base proceed to wire bollard and test.

